



# Orsjo Belysning Streck 2 LED Suspension

LA5371

SOURCE: <https://www.davidvillagelighting.co.uk/product/Orsjo-Belysning-Streck-2-LED-Suspension/18913>

## PRODUCT DESCRIPTION

Designer: Joel Karlsson

### Orsjo Belysning Streck 2 Suspension.

Boasting two light sources and an elegant yet industrial style, the Streck 2 Arm Suspension is perfect for both commercial and residential spaces. This lighting solution is crafted from powder coated steel with brass detailing for an elegant final touch. As always with a Joel Karlsson design, a lot of thought has gone into the details. This includes considering how the electric cable will hang, as this is strongly connected to the longevity of the product. This cable also ensures the light is height adjustable upon installation.

The high quality materials and sleek design of the Streck 2 Pendant means it will suit any interior style, but would be a perfect piece for above your dining room table, office or even throughout a bar, restaurant or cafe.

## PRODUCT SPECIFICATION

- Light Source:** 6W, 2700K, 660 Lumens
- IP Code:** 20
- Dimming:** Dimmable via mains phase dimming.
- Dimensions:** Length: 77cm  
Height: 17cm  
Drop Height: 90-170cm

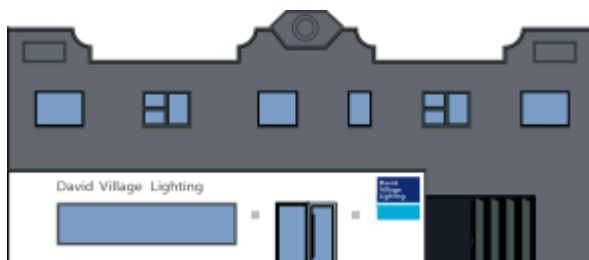
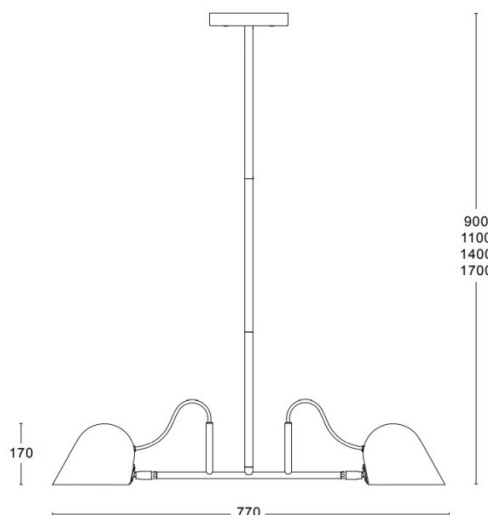

For all sales and technical enquiries, please contact:

+44 (0)114 263 4266

info@davidvillagelighting.co.uk

www.davidvillagelighting.co.uk