

Artemide

Artemide Yanzi 1 LED Suspension

LA5347/S1

SOURCE: <https://www.davidvillagelighting.co.uk/product/Artemide-Yanzi-1-LED-Suspension/18871>

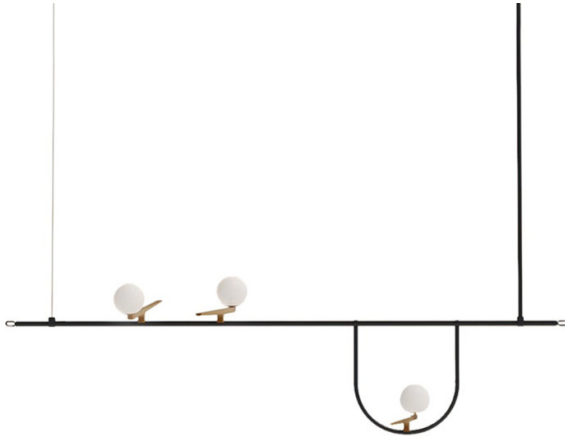

PRODUCT DESCRIPTION

Designer: Neri&Hu

Artemide Yanzi 1 LED Suspension

The Artemide Yanzi 1 Suspension boasts an open system, a lightweight composition that will bring tranquillity and light into any space. Neri & Hu, the designer duo behind the Yanzi Collection, believe that research is a tool for design. For this luminaire, they drew inspiration from the birds resting on scaffolding. The Yanzi is an amalgamation of refined yet essential, cold and warm materials. The 'swallows' of the Yanzi lights appear to rest freely on the slender steel stem. The silhouette of the Yanzi 1 Suspension, depicting branches or perches, offers support to the resting 'swallows'.

The avian figures have a brass, minimal body and a spherical glass head, each of which acts as a diffuser for the inner light source. The result is three evenly emitted glows. A unique, almost poetic design that will animate any interior and can create poetic landscapes. An elegant addition to dining areas, atriums, kitchens and even workspaces for an eye-catching accent light.

PRODUCT SPECIFICATION

| | |
|----------------------|--|
| Light Source: | 26W, 3000K, 2122 Lumens |
| IP Code: | 20 |
| Dimming: | Push to make/switch dimming, dimmable using push-to-make switches. Please consult your electrician; additional wiring may be required on-site. |
| Dimensions: | Length: 156cm Depth: 31cm Base: Ø15.2cm Max Height from Ceiling: 104cm |

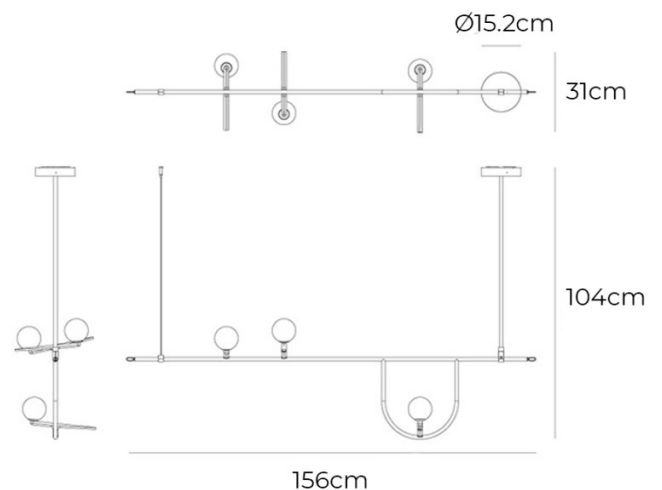



For all sales and technical enquiries, please contact:

+44 (0)114 263 4266

info@davidvillagelighting.co.uk

www.davidvillagelighting.co.uk