

ANGLEPOISE®

Anglepoise Original 1227 Mini Lamp with Wall Bracket

LA3608

SOURCE: <https://www.davidvillagelighting.co.uk/product/Anglepoise-Original-1227-Mini-Lamp-with-Wall-Bracket/16221>

PRODUCT DESCRIPTION

Designer: George Carwardine

Anglepoise Original 1227 Mini Lamp with Wall Bracket



The Original 1227 Mini Wall Light with Bracket is a more compact version of the [Original 1227 Wall Light with Bracket](#), offering the same flexibility in a smaller package. This three-spring, articulated task light is a reinterpretation of the [Original 1227 Desk Lamp](#), launched by Anglepoise in 1935. It provides functional task lighting that can be directed as required, whether above a kitchen island, at a bedside, or at an office desk. Install individually if a direct spotlight is required, in pairs for a sense of balance, or in rows for even lighting.

The Original 1227 Mini Wall Light with Bracket is a great space-saving solution for small rooms. The articulated arm allows the lamp to be moved around to suit requirements and, when not in use, can be folded back against the wall. Available in Linen White, Jet Black, and Dove Grey, the wall light suits a range of classic and contemporary decors in residential or commercial environments alike. Display with other pieces from the [Original 1227 Collection](#) for a cohesive theme that celebrates iconic British lighting.

PRODUCT SPECIFICATION

- Light Source:** 1 x Max 6W E14 LED (Included)
- IP Code:** 20
- Dimming:** In-line on/off switch included on cable.
- Dimensions:** Shade: Ø13cm
 Shade Height: 14cm
 Wall Bracket Depth: 17cm
 Maximum Reach (from wall mount to shade): 72cm
 Cable Length: 180cm

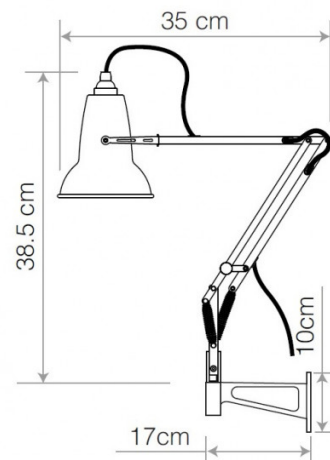



For all sales and technical enquiries, please contact:

+44 (0)114 263 4266

info@davidvillagelighting.co.uk

www.davidvillagelighting.co.uk