

CLEARANCE
OFFERS

Woud Stone Pendant
CLEARANCE

LA11461/CLEARANCE

SOURCE: <https://www.davidvillagelighting.co.uk/product/Woud-Stone-Pendant-CLEARANCE/10002796>



PRODUCT DESCRIPTION

Designer: Philip Bro Ludvigsen

Woud Stone Pendant

BRAND NEW, OVERSTOCK. BOXED IN B-GRADE NON-ORIGINAL PACKAGING.
1 x Brushed Metal Available.

The Woud Stone Pendant is characterised by its soft shapes and minimalistic expression. Inspired by the softness and shapes of beach stones, made during their life in water, sand and wind. The pendants are designed with the idea of stacking two round stones, which is one of the oldest human expressions.

The Stone pendant effortlessly projects a calming downlight onto the area below, perfect for above dining tables, kitchen counters and bedside tables. While the finish allows this luminaire to adapt to a variety of interior styles.

PRODUCT SPECIFICATION

- Light Source:** 1 x Max 25W E14 (Excluded)
- IP Code:** 20
- Dimming:** Dimmable via mains phase dimming.
- Dimensions:** Shade: Ø15.9cm
Shade Height: 16cm
Cable Length: 300cm

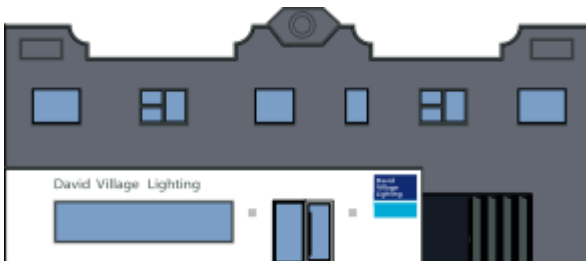
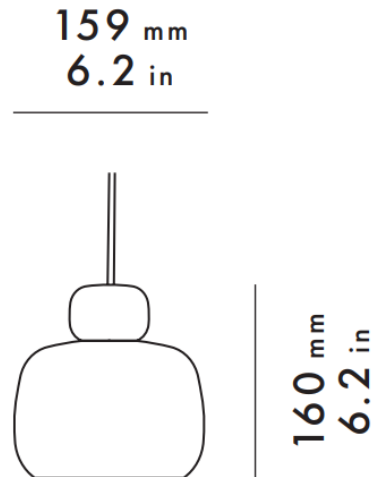

For all sales and technical enquiries, please contact:

+44 (0)114 263 4266

info@davidvillagelighting.co.uk

www.davidvillagelighting.co.uk