

CLEARANCE
OFFERS

LA11424/CLEAR

Bover Platet A/02 Wall Light CLEARANCE

SOURCE: <https://www.davidvillagelighting.co.uk/product/Bover-Platet-A02-Wall-Light-CLEARANCE/10002775>



PRODUCT DESCRIPTION

Designer: Christophe Mathieu

Bover Platet A/02 Wall Light

BRAND NEW, OVERSTOCK. BOXED IN A-GRADE ORIGINAL PACKAGING.

4x Black/Antique Brass Available.

The Bover Platet Wall Light was designed by Christophe Mathieu, who was inspired by typical industrial-looking wall lamps in La Escala. This lighting solution consists of a slender black aluminium frame and a striking antique brass shade. Platet is a luminaire that recovers the idea and structure of the classic industrial-looking wall lamps, giving it a new concept, to adapt it to current times and needs in terms of technology and design.

The inner LED light source of the Bover Platet A/02 Wall Light is projected down onto the surface below, providing a warm, indirect illumination that can adapt to a variety of interiors. This luminaire is an elegant addition to kitchens, hallways, bedrooms and reading nooks.

PRODUCT SPECIFICATION

Light Source: 4.2W, 2700K, 323 Lumens

IP Code: 20

Dimming: Dimmable via Triac dimming.

Dimensions: Height: 41cm
Shade: Ø20cm
Depth: 30cm
Wall Mount Height: 15cm
Wall Mount Width: 5cm

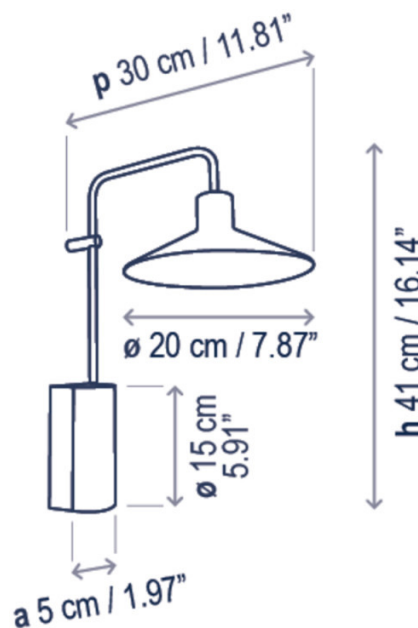



For all sales and technical enquiries, please contact:

+44 (0)114 263 4266

info@davidvillagelighting.co.uk

www.davidvillagelighting.co.uk